

# VS-50XLF70S

## 50" XGA Display Wall Cube

70 Seventy Series:



FEATURING



### 1: INTELLIGENCE:

- Advanced Smart Lamp System
- Advanced Color Space Control
- Digital Gradation Circuit

### 2: FLEXIBILITY:

- Custom System Configuration
- Easily Upgradable

### 3: INTERNAL PROCESSING:

- Capable of up to 6 windows per display (with no "desktop image")

### 4: AUTO-BALANCING:

- Dynamic Color and Brightness Balancing

### 5: EASY SETUP:

- Auto Geometry and Color Adjustment
- Front or rear maintenance available

### 6: DURABILITY:

- Color Wheel and Fan Wheel Built to Last Over 11 Years of 24/7 Use

### 7: REDUNDANCY

- Input Redundancy for Mission-Critical Applications



# VS-50XLF70S



## Dimensions VS-50XLF70S

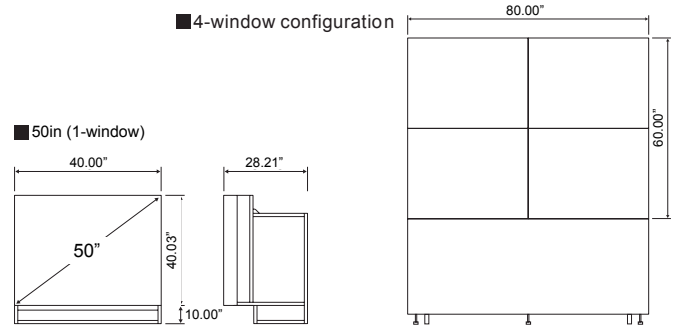

### 50 inch", Front Maintenance DLP® Display Cube

DISPLAY TECHNOLOGY	1-Chip DLP™ (0.7" DMD 1-Chip)
NATIVE RESOLUTION	XGA (1024 x 768)
ESTIMATED SCREEN SIZE	50 inch diagonal
SCREEN TYPE	Black Stripe
SCREEN TO SCREEN GAP	0.2mm - 2.0mm
VIEWING ANGLE	Horizontal: 180 (1/2 gain +/- 38 ) Vertical: 60 (1/2 gain +/- 10 )
BRIGHTNESS	Bright mode: 1,150 cd/m <sup>2</sup> (typ.) Normal mode: 1,010 cd/m <sup>2</sup> (typ.)
LAMP CONFIGURATION	Single Lamp
ESTIMATED LAMP LIFE	10,000 hours (Normal mode) 6,000 hours (Bright mode)
PRODUCT DIMENSIONS	40.00 x 40.03 x 28.21 (W x H x D in)
WEIGHT	154 lbs.
POWER CONSUMPTION	230W @ 132W Normal Lamp Mode, 260W @ 150W Bright Lamp Mode
CONTROL SIGNAL INPUT/OUTPUT	RS-232C: D-Sub 9 pins x 2 (input, output) Mitsubishi original control link; Wired Remote: F3.5 Jack; IR Receiver, LAN Input, Rear LED Notification Screen, Front LED Indicator
INPUT SCANNING FREQUENCY	Horizontal: 31.5kHz – 78kHz Vertical: 49Hz- 85Hz
OPTIONAL INPUT CARDS (EACH DISPLAY REQUIRES 3 INPUT CARDS)	VC-B70G2 - INPUT CARD for Analog RGB Signals (5 BNC x 1 / D-Sub mini 15 pin x 1) VC-B70D2 - INPUT CARD for Digital Video Signals (DVI-D x 2) VC-B70V2 - INPUT CARD for Analog Video Signals (3 BNC x 2) VC-B70DC - INPUT CARD for Daisy Chain (D-Sub 15 x 1 / DVI-D x 1 / 3 BNC x 1) VC-B70SD1 - INPUT CARD for SDI Signals (2 BNC)
OPTIONAL ACCESSORIES	S-A70E - Motorized Adjustment Tool S-70LA - Spare lamp (Standard 132/150W)
ALTERNATE MODEL AVAILABLE	VS-50XLF70B - with black bead screen (specs vary by model)

SPECIFICATIONS AND DATA SUBJECT TO CHANGE WITHOUT NOTICE



MITSUBISHI DIGITAL ELECTRONICS AMERICA, INC.  
Presentation Products Division  
Toll Free: 888.307.0349  
Email: [ppdinfo@mdea.com](mailto:ppdinfo@mdea.com)  
[www.mitsubishi-presentations.com](http://www.mitsubishi-presentations.com)

Canada  
Mitsubishi Electric Sales Canada Inc.  
Information Technologies Group  
Phone: 905.475.7728  
[www.mitsubishielectric.ca](http://www.mitsubishielectric.ca)